

FlexLambda Kit

Compact Wavelength Selection Unit

- Software-controlled wavelength selector for visible and NIR spectral range
- High transmission rate for highest sensitivity
- No affection to polarization and pulse width of the emission signals
- Fully integrated into SymPhoTime 64 software
- Compatible with widefield and confocal microscopes

Applications

- Semiconductor wafer testing and analysis
- Investigating solar cell materials and perovskites
- Studying minerals and crystals
- Analyzing polymers and composites
- Characterizing LED materials and displays
- Wavelength dependent single emitter studies

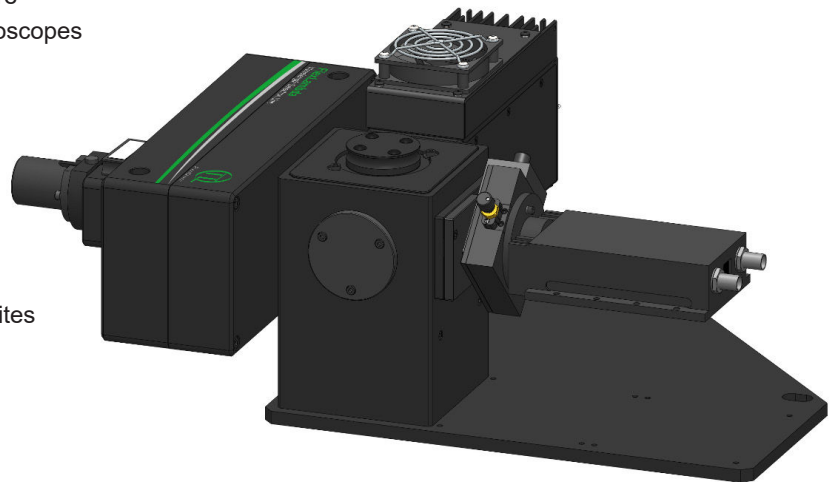

Kit Configuration

FlexLambda is offered as part of a complete measurement solution. Customers who already own compatible PicoQuant components can integrate FlexLambda into their existing setup without repurchasing these items.

Required components :

- FlexLambda, fiber-coupled
- 50 μm multimode fiber
- A supported PicoQuant timing electronics unit: HydraHarp 400/500, MultiHarp 150/160, PicoHarp 300/330, or TimeHarp 260 Nano/Pico Dual
- SymPhoTime 64 software

Optional components:

- Compatible detectors, e.g. PicoQuant PMA Hybrid series, Excelitas SPADs, or MPD PDM series detectors
- Multi-channel detection unit (LSM tower) for up to 4 detector
- Detection optics such as dichroic beamsplitters, short-, long-, or bandpass filters and neutral density filters

In many areas of material science, including semiconductors, photovoltaics, and nanomaterials, characterizing photophysical properties requires selective access to specific emission wavelengths. Whether isolating spectral features, distinguishing recombination pathways, or comparing device performance, flexible and precise wavelength selection is essential. Traditionally, this is achieved using sets of discrete bandpass filters or monochromators, each with limitations in flexibility, speed, or photon efficiency.

The FlexLambda Kit provides a fast, flexible, and reliable solution for wavelength selection across the visible to near-infrared range. It enables users to quickly set spectral detection range as well as spectral bandwidth without exchanging any optical components, simplifying measurements across different samples. Designed as a compact and fiber-coupled unit, FlexLambda can be integrated into a wide range of experimental setups, including microscopes for spatially resolved measurements, as well as spectroscopic systems, probe stations, cryostats, or custom optical configurations. It is particularly beneficial in experiments where efficient photon collection is critical, such as time-resolved measurements, by directing all selected photons onto a single detector.

FlexLambda works in combination with PicoQuant's detection technologies, such as TCSPC electronics, enabling wavelength-dependent time-resolved as well as steady-state measurements. Its flexible architecture supports different detector types and configurations, adapting to the specific requirements of each application. Fully integrated into SymPhoTime 64, the FlexLambda Kit enables intuitive system control and synchronized data acquisition, supporting workflows such as wavelength-selected decays, steady-state analysis, and TRES measurements within a unified measurement environment.

Specifications

Optical specification				
Spectral range	400 - 1000 nm			
Transmission	> 80 % over the whole spectral range			
Spectral resolution (FWHM)	< 5.0 nm			
Bandwidth min.	1.0 nm			
Bandwidth max.	100 nm			
Step width min.	0.1 nm			
Entrance port	FC/APC fiber coupler			
Compatible TCSPC units				
Type	HydraHarp 400/500	MultiHarp 150/160	PicoHarp 300/330	TimerHarp 260 Nano/Pico dual
Compatible detectors				
Type	PMA Hybrid		SPADs (Excelitas/MPD)	
Number of detectors	1 (direct mounting) – 4 (detection unit)			
Operation conditions				
PC requirements	Quad-core CPU > 3 GHz, RAM min. 4 GB			
Operating System	Windows™ 10/11			
Power requirements	220/240 or 110/120 VAC, 50/60 Hz			
Connection	USB 2.0 based			
Software	SymPhoTime 64			
Dimensions and weight				
Dimensions (w × d × h)	245 x 85 x 105 mm			
Weight	3.5 kg			



PicoQuant GmbH
Rudower Chaussee 29 (IGZ)
12489 Berlin
Germany

Phone +49-(0)30-1208820-0
Email info@picoquant.com
Web www.picoquant.com